

General Description

Cartridge Style Pilot Operated Check Valve. For additional information see Technical Tips on pages CV2-CV3.

Features

- Hardened, precision ground parts for durability
- Internal pilot position simplifies manifold design
- All external parts zinc plated

Performance Curve

Pressure Drop vs. Flow (Through cartridge only)

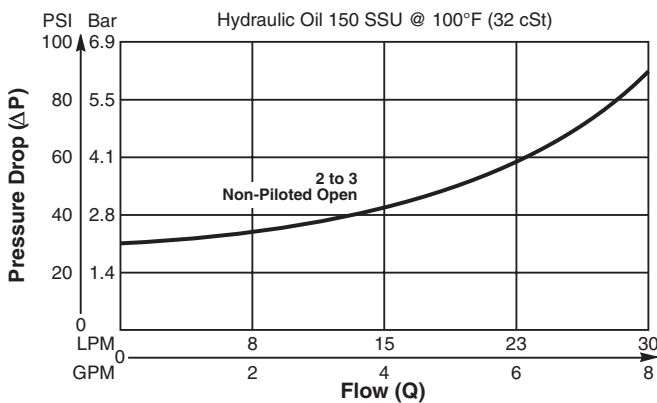

Specifications

Rated Flow	30 LPM (8 GPM)
Maximum Inlet Pressure	350 Bar (5000 PSI)
Leakage at 150 SSU (32 cSt)	2 drops/min. (0.13 cc/min) at 350 Bar (5000 PSI)
Pilot Ratio	4:1
Cartridge Material	All parts steel. All operating parts hardened steel.
Operating Temp. Range/Seals	-37°C to +93°C ("D"-Ring) (-35°F to +200°F) -34°C to +121°C (Nitrile) (-30°F to +250°F) -26°C to +204°C (Fluorocarbon) (-15°F to +400°F)
Fluid Compatibility/Viscosity	Mineral-based or synthetic with lubricating properties at viscosities of 45 to 2000 SSU (6 to 420 cSt)
Filtration	ISO-4406 18/16/13, SAE Class 4
Approx. Weight	0.9 kg (2.0 lbs.)
Cavity	C10-3 (See BC Section for more details)

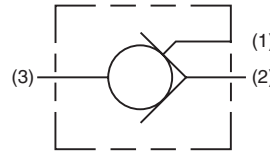
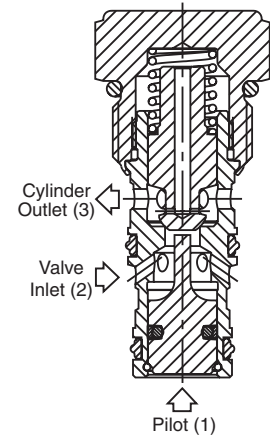

Dimensions Millimeters (Inches)

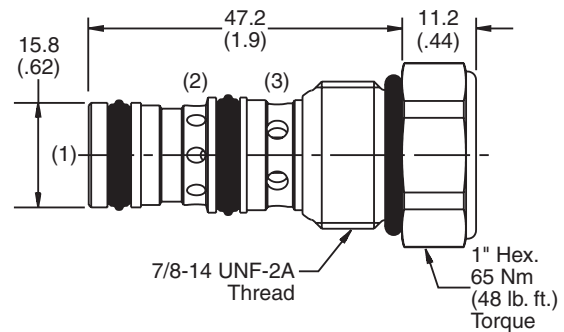

Ordering Information

CPH104P

10 Size
Check Valve

Highlighted represents preferred options that offer the shortest lead times. Other options may be available, but at extended lead times.

Code	Cracking Pressure
Omit	1.4 Bar (20 PSI)

Code	Seals
Omit	"D"-Ring

Kit	Part Number
D-Ring Seal	SK10-3
Nitrile Seal	SK10-3
Fluorocarbon Seal	SK10-3V

Order Bodies Separately
See section BC

B10	—	3	—	8T
10 size		3-Way Cavity		Port Size

Code	Porting / Body Material
8T	SAE-8 / Steel (5000 PSI)

CV Check Valves
SH Shuttle Valves
LM Load/Motor Controls
FC Flow Controls
PC Pressure Controls
LE Logic Elements
DC Directional Controls
SV Solenoid Valves
PV Proportional Valves
CE Coils & Electronics
BC Bodies & Cavities
TD Technical Data